

Catalog No. T144R

Supplement

# Illustrated Parts List

For Style

HF632K272MQA-10

 **Union Special**<sup>®</sup>  
Finest Quality Industrial Sewing Equipment

September 1, 1989

Printed in U.S.A.

Union Special Corporation, One Union Special Plaza, Huntley, IL 60142, U.S.A.  
Union Special, GmbH, Schwabstrasse 33, D-7000 Stuttgart 1, West Germany

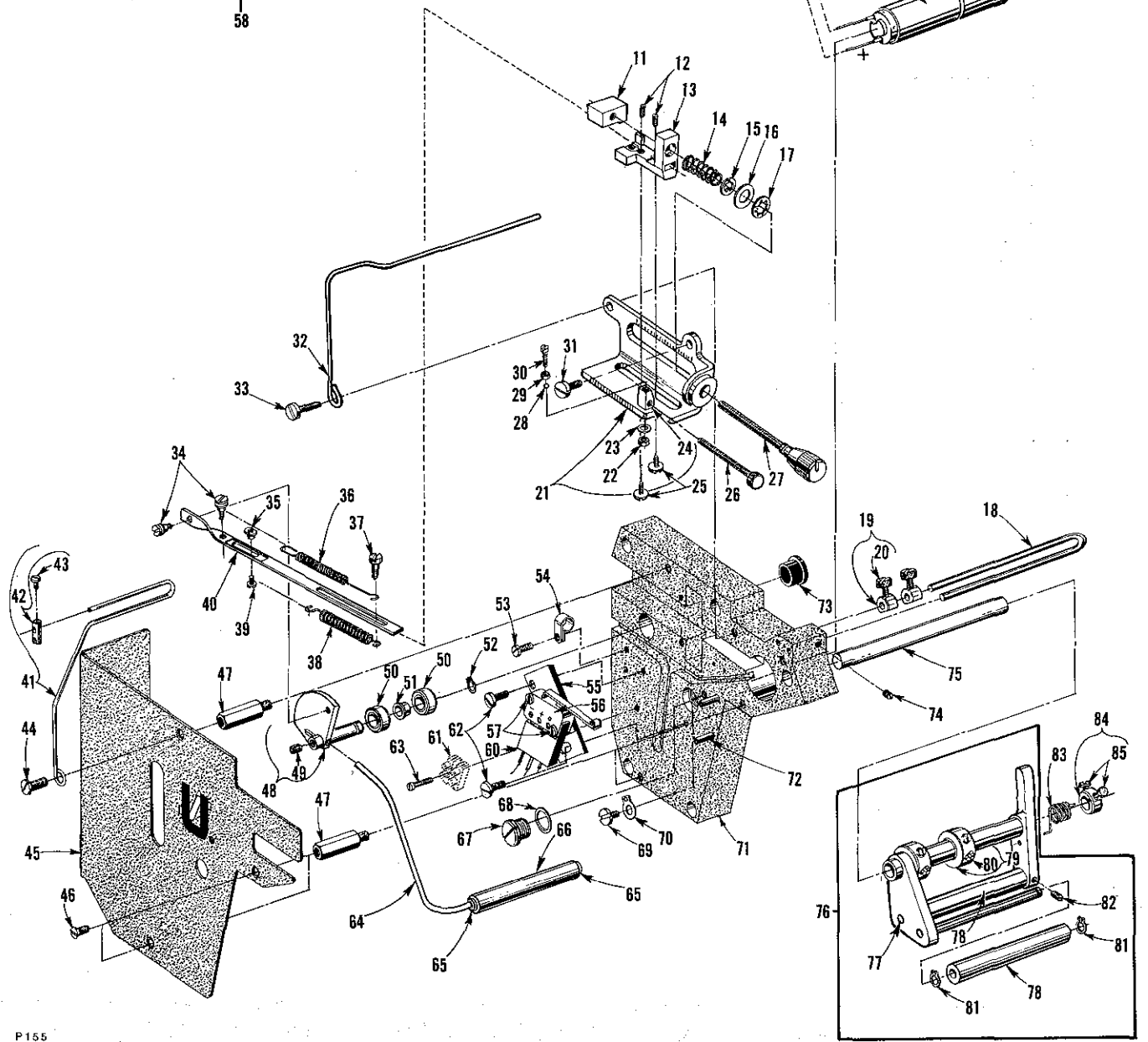
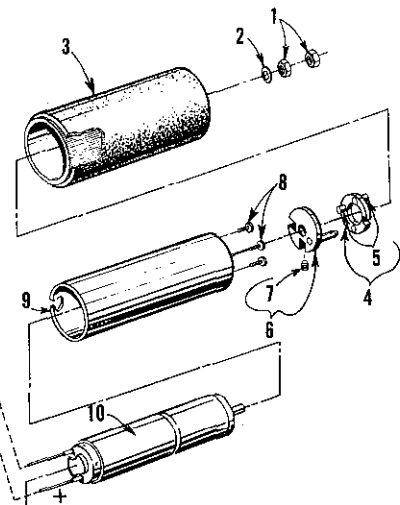
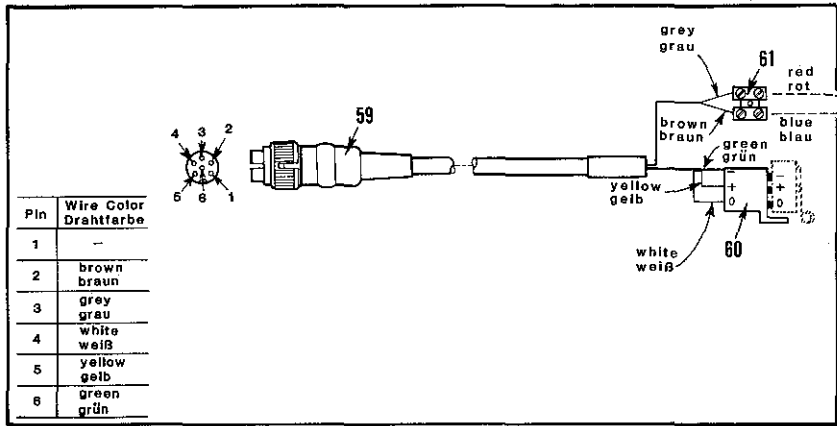

P 155

SINGLE STAGE TOP METERING DEVICE ASSEMBLY

<u>Ref. No.</u>	<u>Part No.</u>	<u>Description</u>	<u>Amt. Req.</u>
1	95259	Nut -----	2
2	95956	Washer -----	1
3	34886 NA	Puller Roller -----	1
4	34886 Q	Clutch Disk -----	1
5	96514 A	Pin -----	3
6	34886 P	Driver -----	1
7	28 C	Set Screw -----	1
8	95178 A	Screw -----	3
9	G50-802	Housing, motor -----	1
10	997YY-451	DC-Micromotor with gear -----	1
11	34886 RA	Nut, spindle -----	1
12	73 C	Set Screw -----	2
13	34886 S	Slide -----	1
14	97015 C	Spring, pressure -----	1
15	96275	Ring, retaining -----	1
16	61451 C	Washer -----	1
17	97136	Cup Spring -----	1
18	34886 B	Strap -----	1
19	G23451 A	Collar -----	2
20	188 D	Screw, thumb -----	2
21	34886 R	Bracket, guide -----	1
22	43443 Q	Nut -----	1
23	33703 TC	Washer -----	1
24	34886 R-2	Nut, spindle -----	1
25	99275	Screw -----	2
26	99340 D	Screw, thumb -----	1
27	99340 C	Screw, thumb -----	1
28	660-459	Ball, plastic -----	1
29	43443 Q	Nut -----	1
30	77 B	Screw -----	1
31	25 S	Screw -----	1
32	52778 X	Lead-in Wire -----	1
33	22548	Screw -----	1
34	99358	Shoulder, screw -----	2
35	99380 D	Nut -----	1
36	96704 B	Spring -----	1
37	99336 C	Screw, shoulder -----	1
38	96727 A	Spring -----	1
39	187 A	Screw -----	1
40	34886 EE	Rod, connecting -----	1
*41	23306 AP	Head Cover Elastic Guide -----	1
*42	23306 AV	Elastic Stop Guide -----	2
*43	25 B	Screw -----	2
*44	88 D	Screw -----	1
45	A10246	Plate, cover, head -----	1
46	22805	Screw -----	3
47	99387 A	Screw, adaptor -----	3
48	34886 E	Lever -----	1
49	22894 X	Screw, set -----	1
50	2161	Bearing, ball -----	2
51	G50-726	Spacer, sleeve -----	1
52 thru 85		See following page	

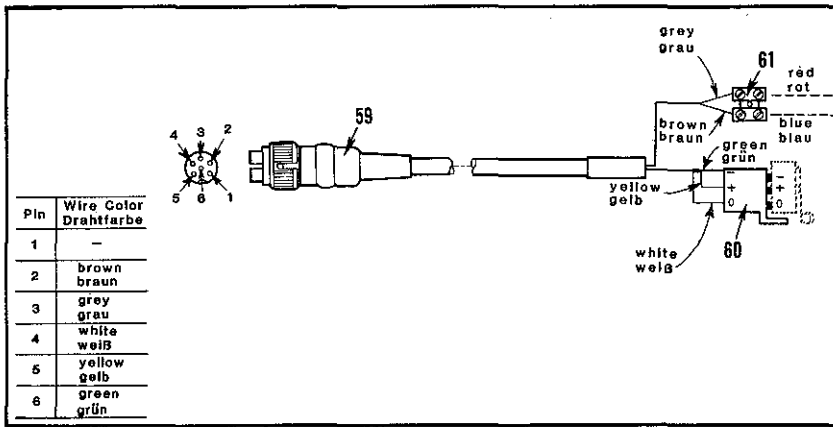

58

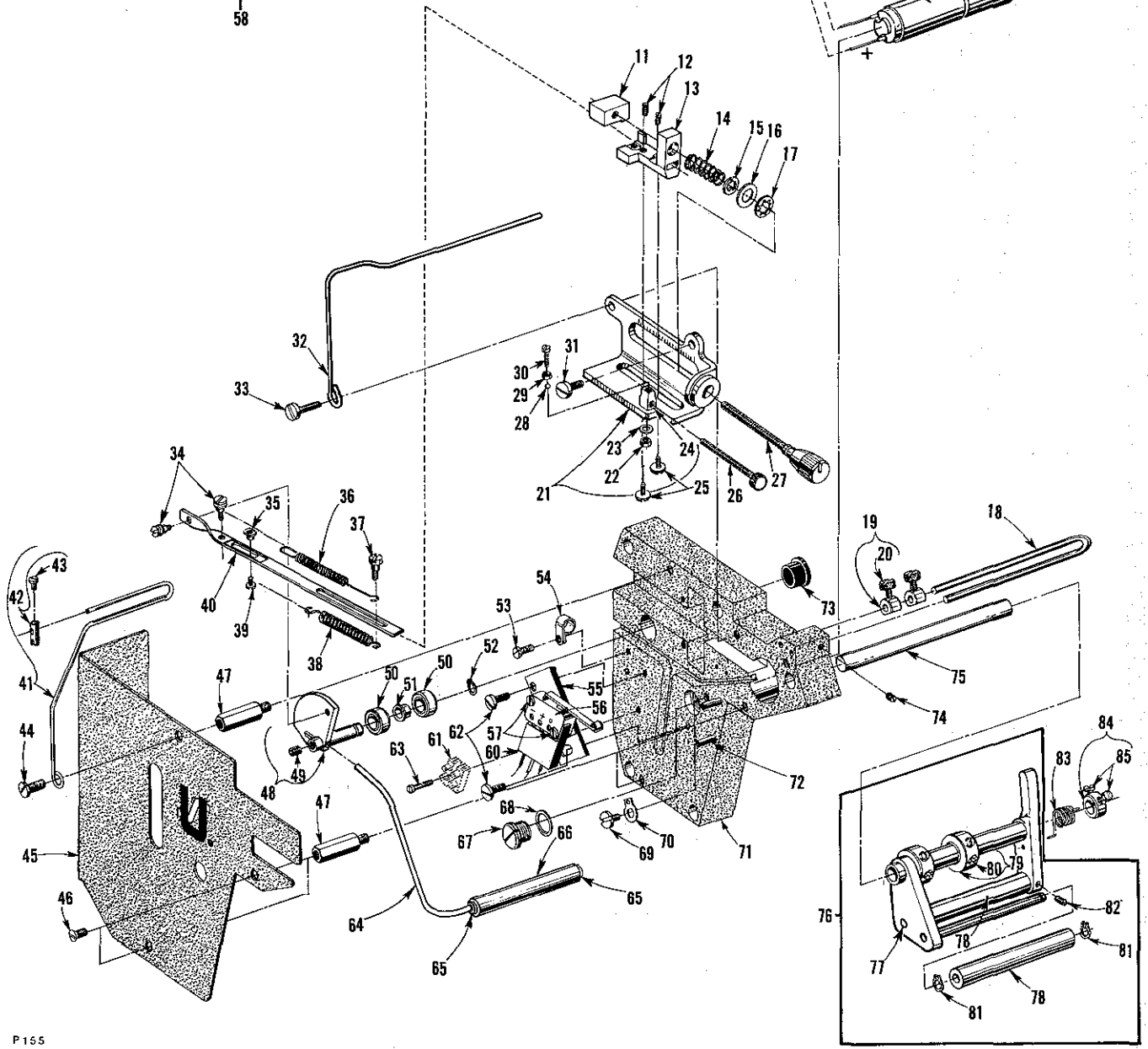
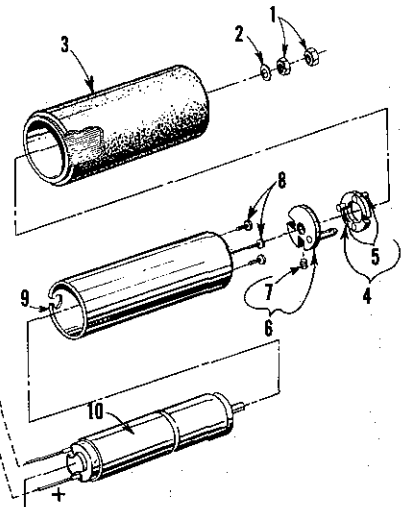

P 155

SINGLE STAGE TOP METERING DEVICE ASSEMBLY

<u>Ref. No.</u>	<u>Part No.</u>	<u>Description</u>	<u>Amt. Req.</u>
1 thru 51		See preceeding page	
52	96252	Ring, retaining -----	1
53	90	Screw -----	1
54	998-358 E	Clamp, cable -----	1
55	34886 M	Plate, for Micro Switch -----	1
56	998-426 B	Switch, micro -----	1
57	95167 A	Screw -----	2
58	90233 DK	Control Cable Assembly -----	1
59	998-364 S	Plug -----	1
60	998-426 BA	Block, connector -----	1
61	998-59	Strip, terminal -----	1
62	22585 A	Screw -----	2
63	95178 BV	Screw -----	1
64	34886 L	Lever, actuating -----	1
65	96252	Ring, retaining -----	2
66	34886 A-6	Roller -----	1
67	22883 B	Screw, plug -----	1
68	C50082 AA	Gasket -----	1
69	25 S	Screw -----	1
70	33744 C	Locking washer for jumper wire -----	1
71	A10246 A	Head Cover -----	1
72	96668	Pin, roll -----	2
73	999-216 K	Plug, oil -----	1
74	22565 C	Screw, set -----	1
75	G50-800	Shaft -----	1
76	34886 A	Tape Guide Assembly -----	1
77	34886 A-3	Shaft -----	1
78	34886 A-6	Roller -----	2
79	39644 P	Collar -----	2
80	98	Screw -----	4
81	666-199	Ring, retaining -----	2
82	28 C	Screw, set -----	1
83	97116	Spring, torsion -----	1
84	34388	Collar -----	1
85	22562	Screw -----	2

\*Ref. No. 41, 42, 43 and 44 are not part of Metering Device Assembly.

#Complete Metering Device Assembly can be ordered under Part No. 29986 DN.

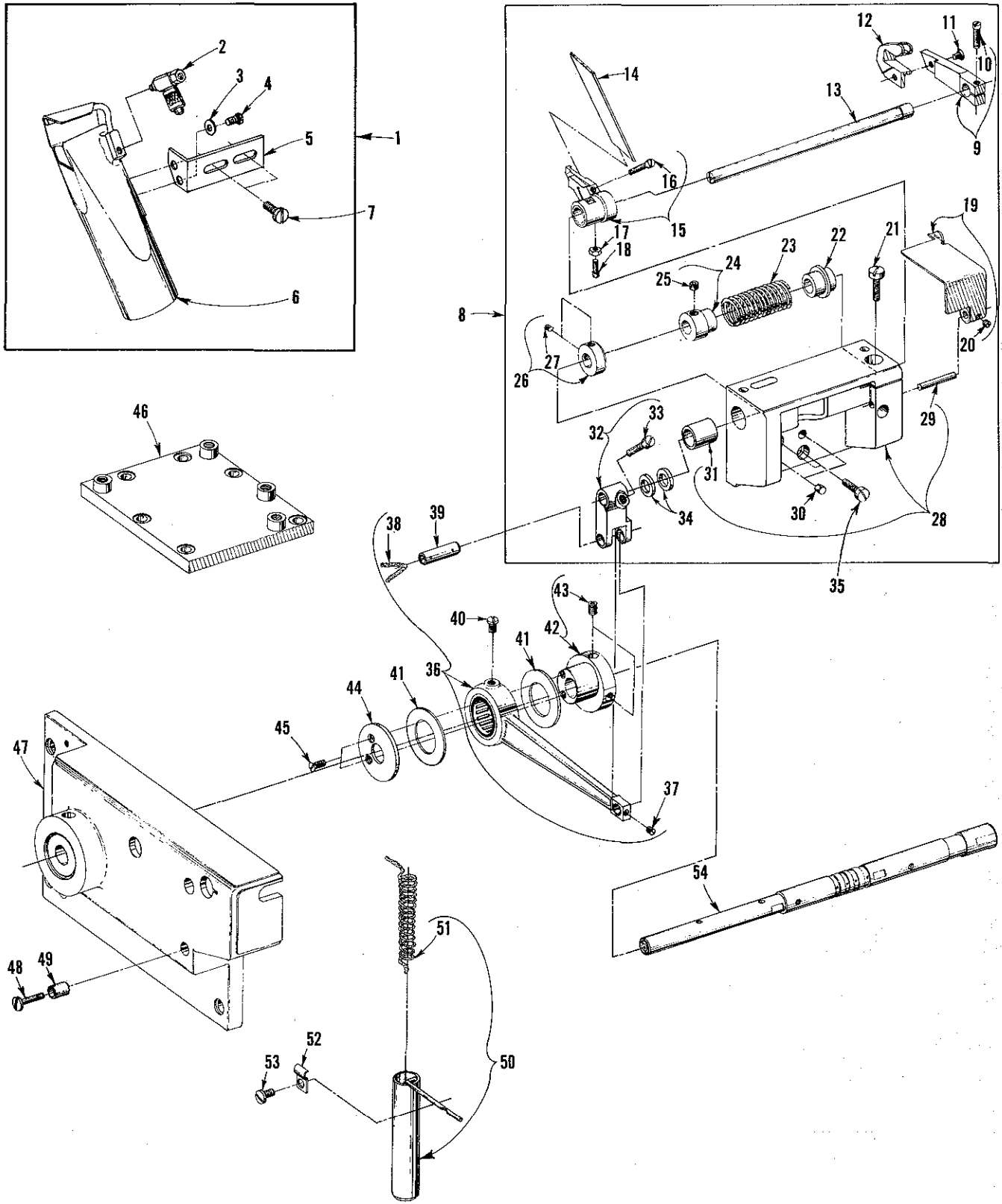

FABRIC UNDERTRIMMER AND RELATED PARTS

<u>Ref. No.</u>	<u>Part No.</u>	<u>Description</u>	<u>Amt. Req.</u>
1	50373 CR	Vacuum Tube Assembly -----	1
2	999-175 DA	Fitting -----	1
3	41358	Washer -----	2
4	J87 J	Screw -----	2
5	50373 CR-1	Bracket -----	1
6	1223019	Tube, vacuum -----	1
7	88 D	Screw -----	2
8	29924 B	Undertrimmer Assembly -----	1
9	34771	Holder, knife (upper) -----	1
10	22729 D	Screw -----	1
11	95435	Screw -----	1
12	34770 AH	Knife, upper -----	1
13	50373 B	Shaft, knife drive -----	1
14	34749 AH	Knife, lower -----	1
15	34750 C	Holder, knife (lower) -----	1
16	22729 E	Screw -----	1
17	51250 C	Nut -----	1
18	22797	Screw -----	1
19	50373 F	Guide, edge -----	1
20	22743	Screw -----	1
21	22596 H	Screw -----	1
22	50373 D	Collar, spring -----	1
23	97010 D	Spring -----	1
24	50373 E	Collar, pressure -----	1
25	22894 W	Screw -----	1
26	34334 D	Collar, thrust -----	1
27	22565 C	Screw -----	2
28	50373	Housing, undertrimmer -----	1
29	96529	Pin, hinge -----	1
30	96531	Pin, dowel -----	2
31	50373 A	Bushing, left -----	1
32	34771 AA	Lever, clamp -----	1
33	93	Screw -----	1
34	41332 J	Washer, thrust -----	2
35	22517	Screw -----	2
36	50373 CE	Connecting rod, knife drive -----	1
37	22894 Y	Screw -----	1
38	666-149	Felt -----	1
39	G51054	Pin, connection -----	1
40	22570	Screw -----	1
41	50373 CD	Washer, non-metallic -----	2
42	50373 CB	Eccentric, knife drive -----	1
43	22894 AD	Screw -----	2
44	50373 CC	Plate, retaining -----	1
45	22766	Screw -----	2
46	50382 BE	Cover, feed chamber (top) -----	1
47	50373 CF	Cover, end -----	1
48	22541 A	Screw -----	2
49	50336 L	Ferrule, locating (end cover) -----	2
50	50373 CN	Reservoir, oil -----	1
51	1204002	Wick yarn, specify length when ordering - as req.	
52	50373 CP	Clamp -----	1
53	22569 F	Screw -----	1
54	50373 CA	Mainshaft, left -----	1

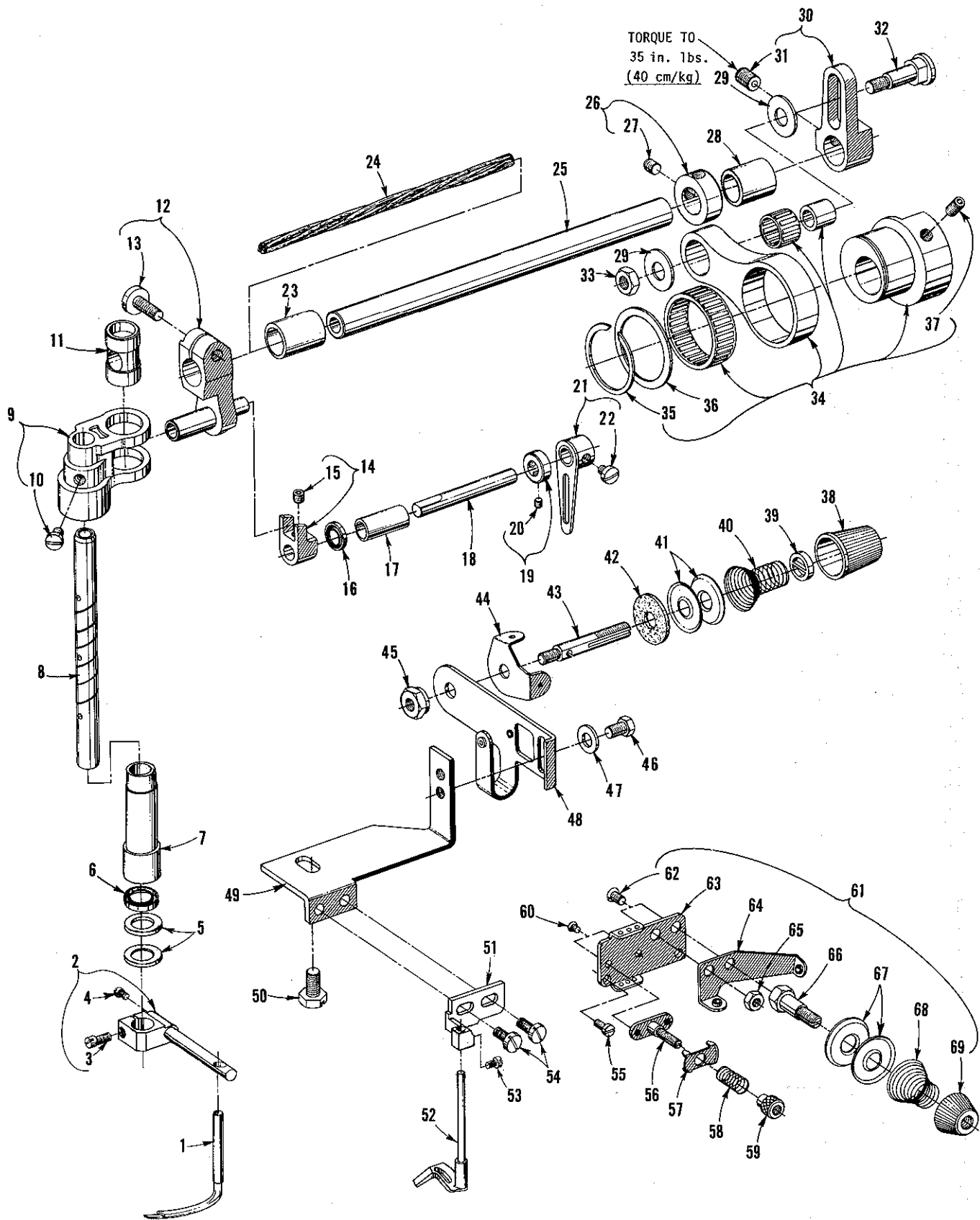



SPREADER AND SPREADER DRIVING MECHANISM

<u>Ref. No.</u>	<u>Part No.</u>	<u>Description</u>	<u>Amt. Req.</u>
1	34845 B	Spreader -----	1
2	34846 B	Holder, spreader -----	1
3	22562 B	Screw -----	1
4	77	Screw -----	1
5	54274 P	Washer, thrust -----	2
6	660-739	Seal, oil -----	1
7	C50047 C	Bushing, spreader holder shaft -----	1
8	C50047 B	Shaft, spreader holder -----	1
9	C50047 D	Lever, spreader holder shaft -----	1
10	88 A	Screw -----	2
11	C50047 F	Pin, link -----	1
12	C50049 E	Arm, rocker shaft -----	1
13	22548	Screw -----	1
14	C50092 Y	Arm, driving lever -----	1
15	22894 W	Screw -----	1
16	660-966	Seal, oil -----	1
17	C50036 AD	Bushing, spreader take-up -----	1
18	C50092 X	Shaft -----	1
19	C50036 AE	Collar, thrust -----	1
20	28 C	Screw -----	2
21	C50092 Z	Take-up, spreader thread -----	1
22	88 A	Screw -----	1
23	C50049 D	Bushing, spreader rocker shaft (left) -----	1
24	WO-2	Yarn, Columbia, 6 inches (152.4mm) long -----	6
25	C50049 B	Shaft, spreader rocker -----	1
26	56335 D	Collar, thrust -----	1
27	95	Screw -----	2
28	C50049 C	Bushing, spreader rocker shaft (right) -----	1
29	53636 C	Washer -----	2
30	C50052	Lever, rocker shaft -----	1
31	22894 X	Screw -----	1
32	C50052 A	Stud, connecting -----	1
33	18	Nut -----	1
34	29126 EM	Spreader Drive Eccentric Assembly -----	1
35	999-215	Ring, retaining -----	1
36	C50036 AC	Washer, thrust -----	1
37	22894 J	Screw -----	2
38	39592 AA	Nut, spreader tension -----	1
39	39592 AK	Ferrule, tension spring -----	1
40	50392 M	Spring, tension, spreader thread -----	1
41	39592 AD	Disc, tension -----	2
42	39592 AF	Felt, tension disc -----	1
43	C50092 AC	Post, tension -----	1
44	C50092 T	Eyelet, tension -----	1
45	39592 AH	Nut, tension post -----	1
46	22519	Screw -----	2
47	35032 H	Washer -----	2
48	C50092 V	Bracket, spreader tension post -----	1
49	C50044 N	Bracket, mounting -----	1
50	22882	Screw -----	1
51	50345 B	Bracket, mounting -----	1
52	50373 CQ	Guide, spreader thread -----	1
53	77	Screw -----	1
54	94	Screw -----	2
55	605 A	Screw -----	2
56	C50092 U	Post, nipper (base) -----	1
57	57 WB	Plate, spring -----	1
58	15438 C	Spring -----	1
59	51959 D	Nut, tension -----	1
60	22716 A	Screw -----	2
61	29475 BT	Spreader Thread Tension Assembly -----	1
62	22766	Screw -----	2
63	C50044 T	Plate, mounting (thread guide) -----	1
64	C50092 W	Guide, spreader thread -----	1
65	41071 G	Nut -----	1
66	C50036 AF	Post, spreader tension -----	1
67	39592 AD	Disc, tension -----	2
68	39592 AR-1	Spring, tension -----	1
69	57892 B	Nut, spreader tension post -----	1

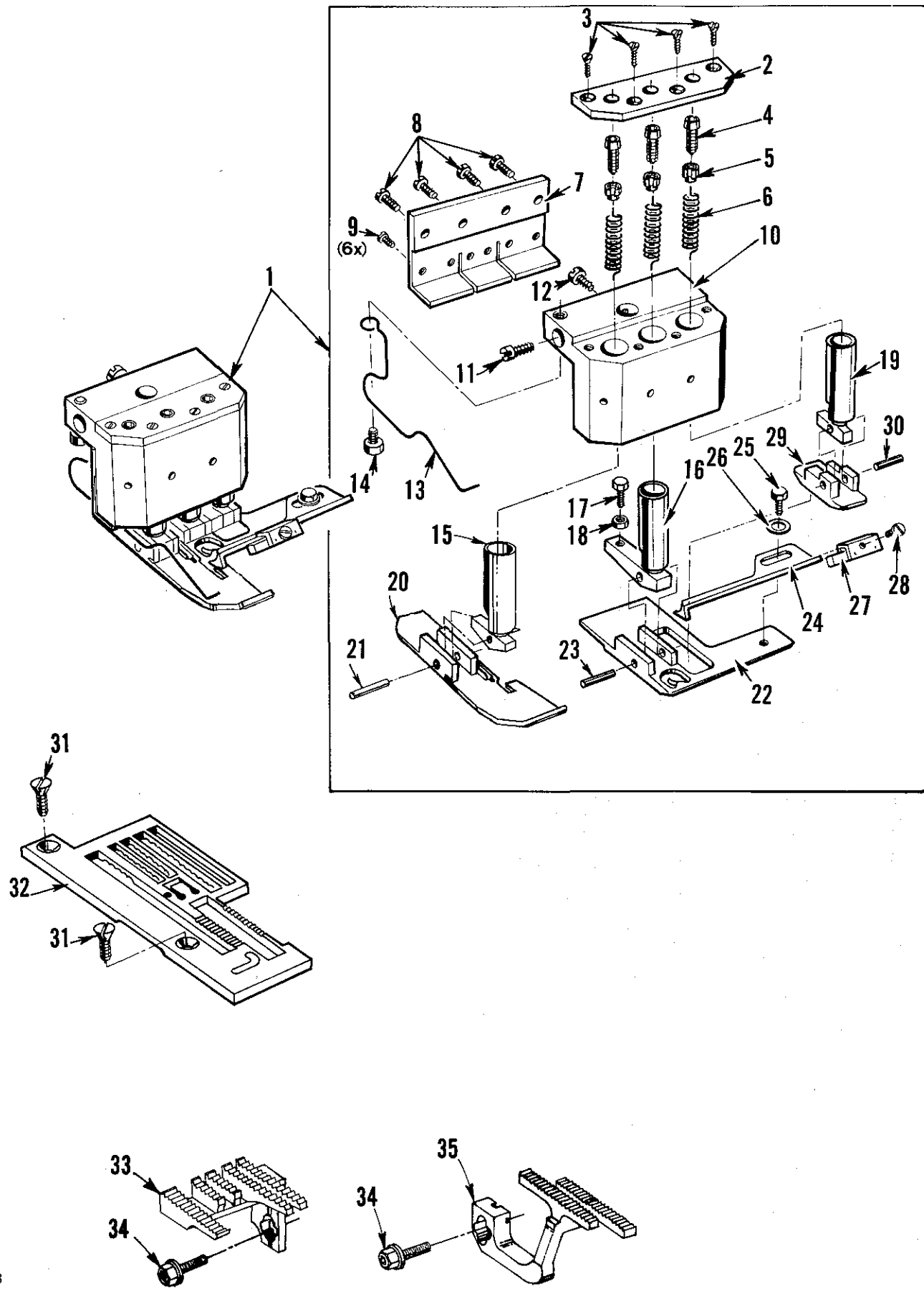

P158

SEWING COMBINATIONS FOR HF632K272MQA-10

<u>Ref. No.</u>	<u>Part No.</u>	<u>Description</u>	<u>Amt. Req.</u>
1	34820 TD-10	Presser Foot Assembly -----	1
2	34830 HA	Plate, cover -----	1
3	99316	Screw -----	4
4	99371 C	Screw, pressure -----	3
5	99395 A	Nut, pressure -----	3
6	97015 A	Spring, pressure -----	3
7	34830 HB	Plate, stop -----	1
8	22738	Screw -----	4
9	22738 H	Screw -----	6
10	34830 AA	Shank -----	1
11	77 B	Screw -----	1
12	77 L	Screw -----	1
13	34830 NA	Spring -----	1
14	99371 D	Screw -----	1
15	34830 ED	Guide -----	1
16	34830 EC	Guide -----	1
17	99339 A	Screw, hex -----	1
18	43443 Q	Nut, lock -----	1
19	34830 EA	Guide -----	1
20	34830 BA-8	Section, yielding (left) -----	1
21	96537 E	Pin, parallel, 1.5mm dia. -----	1
-	96537 EA	Pin, parallel, 1.49mm dia. -----	1
-	96537 EB	Pin, parallel, 1.48mm dia. -----	1
22	34830 TD-10	Bottom, presser foot -----	1
23	96537 E	Pin, parallel, 1.5mm dia. -----	1
-	96537 EA	Pin, parallel, 1.49mm dia. -----	1
-	96537 EB	Pin, parallel, 1.48mm dia. -----	1
24	34830 LA	Guide, tape -----	1
25	99373 A	Screw -----	1
26	95956	Washer -----	1
27	34830 MA	Tape Margin Setter -----	1
28	22738 B	Screw -----	1
29	34830 TDA-8	Bottom, presser foot -----	1
30	96532	Pin, parallel, 2.0mm dia. -----	1
-	96532 AA	Pin, parallel, 1.99mm dia. -----	1
-	96532 AB	Pin, parallel, 1.98mm dia. -----	1
31	87	Screw -----	2
32	34824 TDA-10	Plate, throat -----	1
33	50305 F	Feed dog, main -----	1
34	22569 AD	Screw, feed dog -----	2
35	50326 K	Feed dog, differential -----	1
#	51292 F-5	Spring, needle thread tension -----	2
#	51292 F-8	Spring, needle thread tension -----	2
#	51292 F-2	Spring, looper thread tension -----	1

#Parts not shown on picture plate.

